



# SuperJet-S- Eutalloy®

Modular Spray-Fuse System for  
Wear Protective Coatings  
with Eutalloy® Powder Alloys



## New, re-engineered design improvements

- **Enhance** safe streamline flows of gases and powder feeding through the system circuits
  - **Increase** powder deposition rates on massive parts or thick sections
    - **Ensure** finer deposit control on critical corners or thin edges
  - **Minimise** fused powder overspray and costly post machining operations
- **Prolong** the service life of industrial parts and raise industrial productivity

# SUPERJET-S- Eutalloy®

The Eutalloy® process applies protective, surface engineered coatings on industrial machine parts subject to wear in order to prolong their service life performance. A wide range of Eutalloy® selffluxing, powder alloys may be sprayed, fused and metallurgically bonded using the latest SuperJet -S- delivery system. Independent approvals and extensive field tests assure new quality standards for spray fusing performance, power and precision in the fields of preventive maintenance and repair applications.

## Multi-Purpose, Modular System

SuperJet -S- Eutalloy® is a multi-purpose powder delivery system which can easily be adapted for surface engineering coatings to protect or repair either flat metallic surfaces, fine precision edges or rotating cylindrical parts.

### **Unique benefits of the modular SuperJet -S- delivery system include:**

- Fast manual assembly of the torch with easily rotated tip assembly for positional spraying work.
- Complete range of integrated tip assemblies, each with its own injector and mixing chamber, to ensure optimum powder alloy feeding at different flame settings.
- All torch components readily accessible for dismantling, cleaning and service maintenance.
- Internal powder channel and nozzle designed for maximum wear resistance, service life and reliability.
- Quick action, gas shut-off trigger for instant re-ignition of original flame settings without gas valve adjustments
- Ergonomic torch design for handling ease, lightness, balance and adjustable heat shield.

### **Exclusive Design Quality Improvements: Body-Handle Assembly**

- Precision CNC machining technology used to assure perfect alignment and trajectory of interlinked gas channels in the forged monoblock body to promote streamlined powder flow thus reducing clogging risks and servicing.
- Manually operated powder control lever is surface hardened to increase its operating wear life in contact with transported powder particle flows.

### **Integrated Tip Assemblies**

#### **A0 S spot precision model**

This new addition is specifically designed for spot or touch-up repairs and coatings with maximum precision and lowest heat input. Typical applications involve small, delicate corners or intricate, thin edges which are otherwise susceptible to local overheating or oxidation.

#### **A1 S and A2 S linear precision models**

The completely redesigned internal nozzle geometry and thermal transfer characteristics create a soft, stable flame with sharper powder shut-off. This ensures even finer control of linear coating deposit profiles during the spray-fuse procedure without general overheating or deformation of the substrate.

#### **B3 S and B4 S standard intermediate models C5 S power model**

- Micromachined interlinking powder flow channels, alignments and nozzles polished for boosting powder delivery performance and speeds
- Optimised flame power focus characteristics of the nozzle restrict powder overspray losses to a minimum which cuts costly cleaning operations.
- Stainless steel swan neck better withstands reflected flame heat and enhances service life.
- Adjustable heat shield designed for optimum protection in different working positions.

# Superjet -S- Eutalloy® Kits

The SuperJet -S- Eutalloy® basic kit is supplied in a convenient carrying/ storage case containing the necessary accessories for rapid and easy assembly but without supplementary tip assemblies or Eutalloy® powders.

Depending on specific application needs, the basic kit may be completed with an appropriate choice of tip assemblies and Eutalloy® powder alloys. The picture shows a basic kit complete with five tip assemblies, Eutalloy® powder modules and accessories.

- A Torch nozzle
- B Rotatable, interchangeable tip assembly
- C Powder injector
- D Powder feed valve
- E Eutalloy® powder module
- F Powder feed control lever
- G Gas mixer
- H Protective heat shield
- I Quick shut-off trigger
- J Acetylene valve
- K Oxygen valve

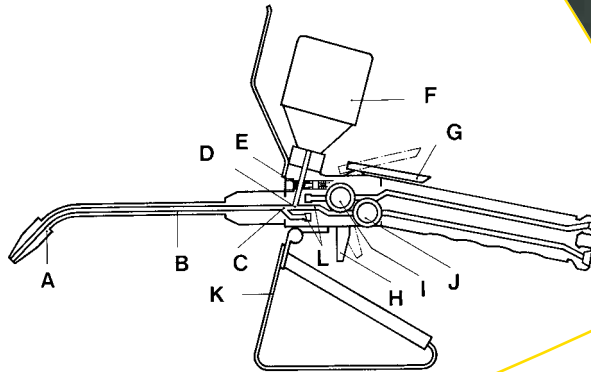

## Superjet -S- Eutalloy® Accessoires



This picture shows the Superjet-S- Eutalloy® basic Kit with accessoires



KoolTip® Kit

Special water cooled tip assemblies called KoolTip® kits are available as an optional accessory.

The KoolTip® kit is recommended whenever the Super-Jet-S- torch is subject to high duty cycle usage or prolonged thermal reflections. The water cooled tip facilitates and speeds up coating operations on large parts or inside internal diameters. An optional, aluminium, refill container may be mounted onto the torch when powder alloys need to be transferred from bulk packages. Refilling is easily executed via the lid without removing the container.

## Superjet -S- Eutalloy® Safety First

The SuperJet -S- Eutalloy® torch is easy to use by semi-skilled operators and meets even the most stringent safety requirements:

- The use of pure oxygen as the carrier gas minimises flashback risks.
- Each tip assembly incorporates safety devices to prevent flashback.
- Quick action shut-off trigger cuts gas flows without affecting original flame settings.
- Adjustable heat shield & longer tip assemblies protect against thermal reverberation.

The partial vacuum created by the oxygen gas flow through the injector draws the Eutalloy® powder into the system. Only after this step, is the acetylene gas allowed into the mixer zone.

Cold Thermal Spraying	Delivery System	Fusion processes
Powder series		Powder series
RotoTec RotoTec LT ProXon MetaCeram CastoPlast	CASTODYN DS 8000	Eutalloy® RW
Hot Thermal Spraying	SUPERJET -S- Eutalloy®	Eutalloy®
	CASTODYN SF LANCE EUTRONIC GAP	Eutalloy® SF EuTroLoy



Castolin Eutectic offers a complete range of Eutalloy® self-fluxing powders and other atomised powder alloy formulations together with appropriate delivery systems to protectively coat industrial tools and machine parts of every kind.

### The Eutalloy® Process

The Eutalloy® process is designed to apply wear protective coatings typically from 0.1 – 3mm thickness, in a single pass, on a variety of metallic parts by using purpose engineered oxyacetylene delivery systems. Special powder alloys are sprayed and fused to create strong, diffusion bonds without melting the substrate thanks to the presence of synergic elements.

Advanced, powder atomisation technology combined with the new SuperJet -S- delivery system facilitates its use for most preventive maintenance and repair applications found in almost every industrial sector.

### CastoDyn® DS 8000

The CastoDyn DS 8000 is designed to be a versatile, multi-purpose powder delivery system for applying the following types of wear resistant, protective coatings:

- “Cold” spray RotoTec two-step alloys, RotoTec LT Low fusion Temperature alloys, ProXon one-step, self bonding alloys and CastoPlast thermoplastic polymers.
- “Cold” spray MetaCeram series of heat resisting alloys and ceramic powders.
- Spray and fuse Eutalloy® RW self-fluxing powder alloys.

### CastoDyn® SF Lance

The CastoDyn SF Lance is an attachment for the CastoDyn DS 8000 to provide simultaneous spraying and fusion capability with high deposition rates and excellent powder yield factors.

This extension lance is designed and optimised for the exclusive use with Eutalloy® SF self-fluxing powder alloys.



*Dilution-free metallurgical bond*

### Eutronic GAP®

The EuTronic GAP process uses a high energy, Plasma Transferred Arc with shielding and powder transport gases to enable high speed deposition of surface engineering coatings.

The EuTroLoy series of powder alloys are formulated for repetitive, highest quality, wear resistant deposits with extremely low dilution and distortion risks.